



SPECIFICATIONS

TITLE: 10.4" HIGHEND TFT LCD MODULE

NUMBER: HLD 1045E REV. 1 PAGE 1 OF 18

DATA DISPLAY AG

**HLD 1045E
10.4 INCH**

**HIGHEND TFT-LCD
DISPLAY**

**PRELIMINARY
SPECIFICATION**

The information given in this document is carefully checked and believed to be reliable. Data Display reserves the right to make changes in product or specification at any time and without further notice. Data Display products are not intended for use in systems in which failures of product could result in personal injury. All mentioned trademarks are registered trademarks of their owner.



SPECIFICATIONS

TITLE: 10.4" HIGHEND TFT LCD MODULE

NUMBER: HLD 1045E REV. 1 PAGE 2 OF 18

1. OVERVIEW

1.1 Description: HLD1045E is a 10.4-inch TFT-LCD (Thin Film Transistor Liquid Crystal Display) module composed of LCD panel, driver ICs, control circuit, and backlight. By applying 6 bit digital data 640 x 480, 262K – color images are displayed on the 10.4-inch diagonal screen. Input power voltage is 5.0V (does not includes power for the backlight). Both 3.3V- CMOS and 5.0V-CMOS voltage levels are acceptable for logic input voltage. Inverter for backlight is not included in this module.

1.2 General Features

ITEM	SPECIFICATION
Display Area (mm)	211.2 x 158.4 (10.39-inch diagonal)
Number of Pixels	640(H) x 480 (V)
Pixel Pitch (mm)	0.33 (H) x 0.33 (V)
Color Pixel Arrangement	RGB Vertical Stripe
Display Mode	Normally White
Number of Colors	262K
Wide Viewing Angle Technology	Optical Compensation Film
Optimum Viewing Angle (Contrast Ratio)	6 O'clock [†]
Brightness (cd/m ²)	400
Power Consumption (W)	8.5
Module Size (mm)	243.0 (W) x 181.6 (H) x 12.2 (D)
Module Weight (g)	530
Backlight Unit	CCFL, Two Lamps, Replaceable

[†] for projects 500 pcs. up also 12:00 V.A. available

1.3 Product Disclaimer

The LCD products listed in this document are not suitable for safety related applications that do not have redundant back-up system(s). In other words, these LCD products are not designed for use as a single source safety related application, and therefore, are not recommended for applications in which human life and/or environment may be affected in the event of the failure of the LCD product. More specifically, if there is no back-up system or product in place that will continue operating the system, the LCD products should not be used in such things as:

- aircraft navigation or aerospace equipment
- nuclear reactor control systems
- any application where failure or inaccuracy might cause death or personal injury (e.g. life support systems) or
- military and submarine critical systems.

The LCD products are designed for typical industrial applications such as, but not are limited to the following: computers, office equipment, industrial controllers, audio and visual equipment, test and measurement devices, communication equipment, point of sale, medical imaging and automotive and various other consumer products. If there are any questions regarding the use, ability or application of these LCD products, please contact Data Display.



SPECIFICATIONS

TITLE: 10.4" HIGHEND TFT LCD MODULE

NUMBER: HLD 1045E REV. 1 PAGE 3 OF 18

2. ABSOLUTE MAXIMUM RATINGS

2.1 Environmental conditions: humidity \leq 85% RH, no condensation

Item	Symbol	Min.	Max	Unit
Power Supply Voltage for LCD	V_{CC}	- 0.3	6.5	V
Operating Temperature	T_{op}	- 10	+ 60	$^{\circ}C$
Storage Temperature	T_{stg}	- 35	+ 80	$^{\circ}C$

3. ELECTRICAL CHARACTERISTICS

3.1 Conditions: TFT-LCD module ambient temperature is 25 $^{\circ}C$

Item	Symbol	Min.	Typ.	Max.	Unit	Remark
Power Supply Voltage for LCD	V_{CC}	4.75	5.00	5.25	V	
Power Supply Current for LCD	I_{CC}		200		mA	
Permissible Input Ripple Voltage	V_{RP}			100	mV _{p-p}	$V_{CC}=+5.0V$
Logic Input Voltage	High	V_{LH}	2.0	V_{CC}	V	
	Low	V_{LL}	0.0	0.8	V	

3.2 Backlight

The table below shows data for one lamp only

The TFT-LCD module has two identical lamps operated independently

Operation of both lamps is required in order to meet all the parameters in the HLD1045E specification.

Item	Symbol	Min.	Typ.	Max	Unit
Lamp Voltage	V_L		580		V
Lamp Current	I_L	3.0	6.5*	7.0	mA
Lamp Starting Voltage	V_S	810			V
at 25 $^{\circ}C$	V_S	1000			V
at 0 $^{\circ}C$	F_L	50		80	kHz
Lamp Frequency					

Note*: For typical luminance of 400 cd/m²



SPECIFICATIONS

TITLE: 10.4" HIGHEND TFT LCD MODULE

NUMBER: HLD 1045E REV. 1 PAGE 4 OF 18

3.3 Notes

V_{CC} turn-on conditions:

$t_1 \leq 10\text{ms}$

$0 < t_2 \leq 50\text{ms}$

$0 < t_3 \leq 50\text{ms}$

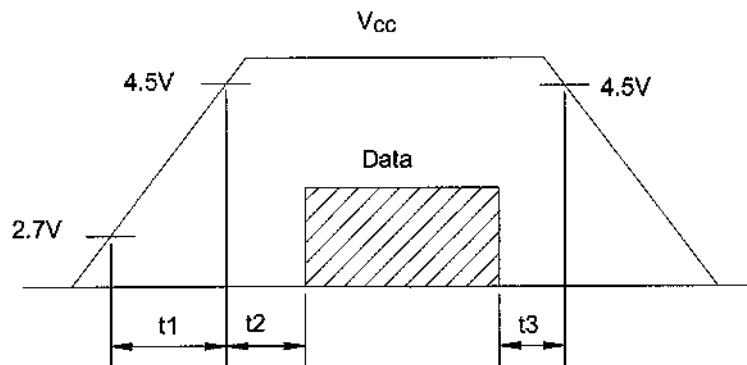

V_{CC} -dip conditions:

$2.7\text{V} \leq V_{CC} < 4.5\text{V}$ and $t_d \leq 10\text{ms}$

$V_{CC} < 2.7\text{V}$

V_{CC} -dip conditions should also follow the V_{CC} turn-on condition

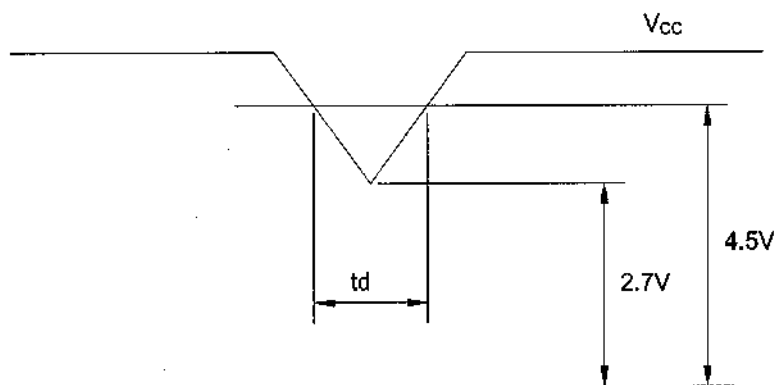

Test condition for I_{CC} typical:

64 gray-bar pattern

480 line mode

$V_{CC} = +5\text{V}$

Test condition for I_{CC} (MAX):

1 x 1 checkerboard, black and white pattern

DC input voltage = 4.75V



4. INTERFACE CONNECTORS PIN ASSIGNMENT

Input connector type (see paragraph 6)

Input connector CN1: DF9B-31P-1V(Hirose)

Input mating connector: DF9B-31S-1V(Hirose)

Input connector pin assignment table

PIN	SYMBOL	FUNCTION
1	GND	Ground*
2	DCLK	Clock signal
3	HD	Horizontal sync signal
4	VD	Vertical sync signal
5	GND	Ground*
6	R0	Red data signal (LSB)
7	R1	Red data signal
8	R2	Red data signal
9	R3	Red data signal
10	R4	Red data signal
11	R5	Red data signal (MSB)
12	GND	Ground*
13	G0	Green data signal (LSB)
14	G1	Green data signal
15	G2	Green data signal
16	G3	Green data signal
17	G4	Green data signal
18	G5	Green data signal (MSB)
19	GND	Ground*
20	B0	Blue data signal (LSB)
21	B1	Blue data signal
22	B2	Blue data signal
23	B3	Blue data signal
24	B4	Blue data signal
25	B5	Blue data signal (MSB)
26	GND	Ground*
27	DENA	Data enable signal
28	V _{CC}	5.0V Power Supply
29	V _{CC}	5.0V Power Supply
30	TEST	This pin should be open. Test signal output for only test use
31	TEST	This pin should be open. Test signal output for only test use

Note: The metal frame of the TFT-LCD module is connected to ground.



SPECIFICATIONS

TITLE: 10.4" HIGHEND TFT LCD MODULE

NUMBER: HLD 1045E REV. 1 PAGE 6 OF 18

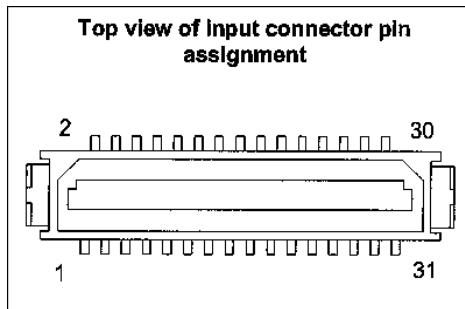

Backlight connector type (see paragraph 6)

Backlight connector (CN2 and CN3): BHR-02(8.0)VS-1N (JST)

Backlight mating connector: SM02(8.0)B-BHS(JST)

Backlight connector pin assignment table:

Pin Number	Symbol	Function
1	CTH	VBLH (High Voltage)
3	CTL	VBLL (Low Voltage)



5. INTERFACE TIMING

5.1 Timing Chart

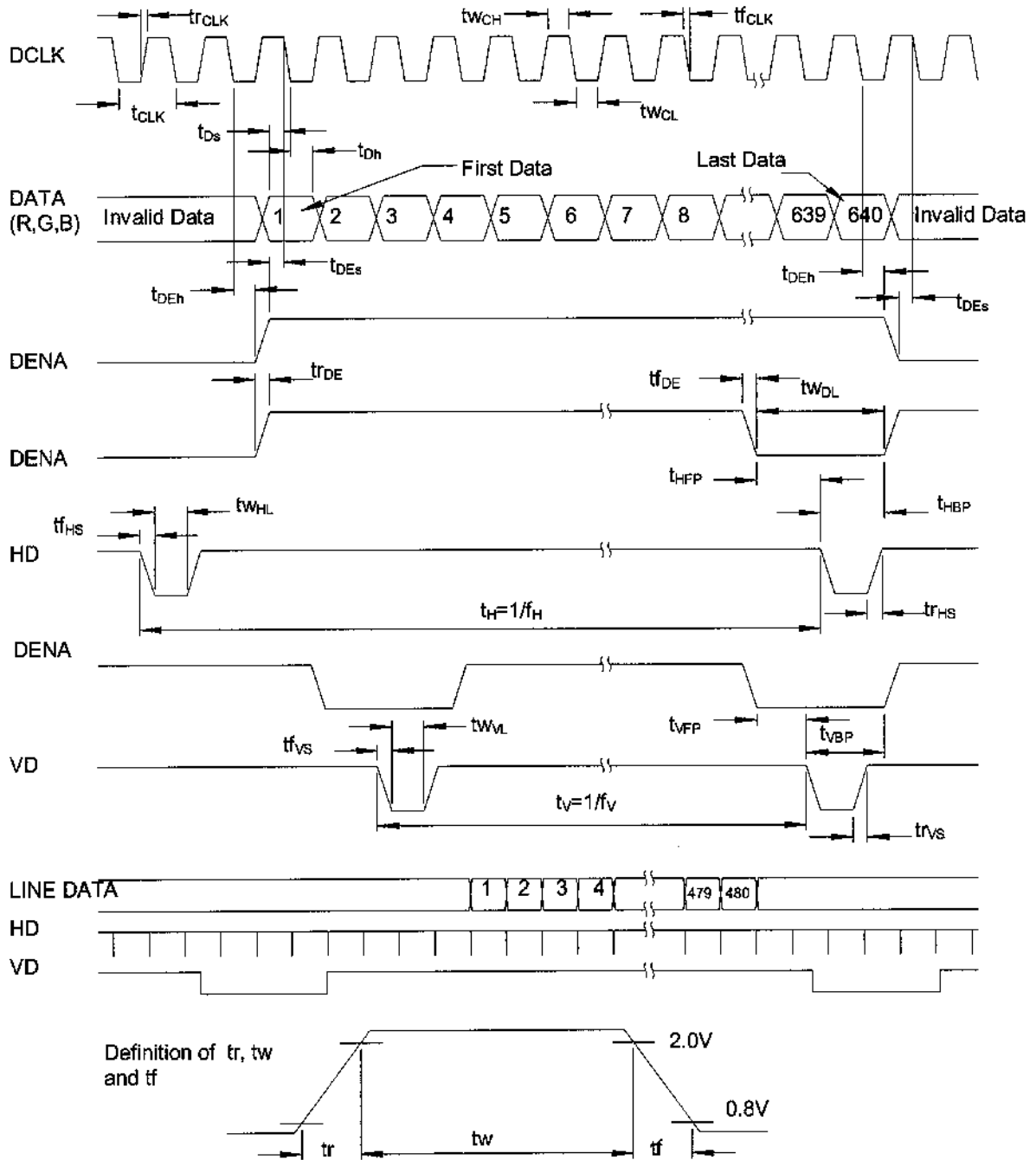



SPECIFICATIONS

TITLE: 10.4" HIGHEND TFT LCD MODULE

NUMBER: HLD 1045E REV. 1 PAGE 8 OF 18

5.2 Timing Specification

ITEM		SYMBOL	MIN	TYP	MAX	UNIT
DCLK	Frequency	f_{CLK}		25		MHz
	Period	t_{CLK}	34,5	40		ns
	Width-Low	tw_{CL}	12			ns
	Width-High	tw_{CH}	12			ns
	Rise Time	tr_{CLK}			5	ns
	Fall Time	tf_{CLK}			5	ns
DATA (R,G,B)	Set up Time	t_{Ds}	5			ns
	Hold Time	t_{Dh}	5			ns
DENA	Set up Time	t_{DEs}	5			ns
	Hold Time	t_{DEh}	5			ns
	Low Time	tw_{DL}	90	160	168	t_{CLK}
	Rise Time	tr_{DE}			5	ns
	Fall Time	tf_{DE}			5	ns
	Horizontal Front Porch	t_{HFP}	0	16		t_{CLK}
	Horizontal Back Porch	t_{HBP}	2	144		t_{CLK}
	Vertical Front Porch	t_{VFP}	1	12		t_H
Vertical Back Porch	t_{VBP}	2	33		t_H	
HD*	Frequency	f_H	27	31,6	38	kHz
	Period	t_H	730	800	808	t_{CLK}
	Width-Low	tw_{HL}	5	96		t_{CLK}
	Rise Time	tr_{HS}			10	ns
	Fall Time	tf_{HS}			10	ns
VD	Frequency	f_V	55	60,0	70	Hz
	Period	t_V	489	525		t_H
	Width-Low	tw_{VL}	3			t_H
	Rise Time	tr_{VS}			10	ns
	Fall Time	tf_{VS}			10	ns

Note: DCLK and HD should be applied continuously at the input connector of the TFT-LCD module during operation, subject to V_{CC} turn-on conditions



5.3 Color Data Assignment

COLOR	INPUT DATA	R DATA						G DATA						B DATA					
		R5	R4	R3	R2	R1	R0	G5	G4	G3	G2	G1	G0	B5	B4	B3	B2	B1	B0
		MSB					LSB	MSB					LSB	MSB					LSB
BASIC COLOR	BLACK	0	0	0	0	0	0	0	0	0	0	0	0	0	0	0	0	0	0
	RED(63)	1	1	1	1	1	1	0	0	0	0	0	0	0	0	0	0	0	0
	GREEN(63)	0	0	0	0	0	0	1	1	1	1	1	1	0	0	0	0	0	0
	BLUE(63)	0	0	0	0	0	0	0	0	0	0	0	0	1	1	1	1	1	1
	CYAN	0	0	0	0	0	0	1	1	1	1	1	1	1	1	1	1	1	1
	MAGENTA	1	1	1	1	1	1	0	0	0	0	0	0	1	1	1	1	1	1
	YELLOW	1	1	1	1	1	1	1	1	1	1	1	1	0	0	0	0	0	0
	WHITE	1	1	1	1	1	1	1	1	1	1	1	1	1	1	1	1	1	1
RED	RED(0)	0	0	0	0	0	0	0	0	0	0	0	0	0	0	0	0	0	0
	RED(1)	0	0	0	0	0	1	0	0	0	0	0	0	0	0	0	0	0	0
	RED(2)	0	0	0	0	1	0	0	0	0	0	0	0	0	0	0	0	0	0
	!																		
	!																		
	RED(62)	1	1	1	1	1	0	0	0	0	0	0	0	0	0	0	0	0	0
	RED(63)	1	1	1	1	1	1	0	0	0	0	0	0	0	0	0	0	0	0
	GREEN	GREEN(0)	0	0	0	0	0	0	0	0	0	0	0	0	0	0	0	0	0
GREEN(1)		0	0	0	0	0	0	0	0	0	0	0	1	0	0	0	0	0	0
GREEN(2)		0	0	0	0	0	0	0	0	0	0	1	0	0	0	0	0	0	0
!																			
!																			
GREEN(62)		0	0	0	0	0	0	1	1	1	1	1	0	0	0	0	0	0	0
GREEN(63)		0	0	0	0	0	0	1	1	1	1	1	1	0	0	0	0	0	0
BLUE		BLUE(0)	0	0	0	0	0	0	0	0	0	0	0	0	0	0	0	0	0
	BLUE(1)	0	0	0	0	0	0	0	0	0	0	0	0	0	0	0	0	0	1
	BLUE(2)	0	0	0	0	0	0	0	0	0	0	0	0	0	0	0	0	1	0
	!																		
	!																		
	BLUE(62)	0	0	0	0	0	0	0	0	0	0	0	0	1	1	1	1	1	0
	BLUE(63)	0	0	0	0	0	0	0	0	0	0	0	0	1	1	1	1	1	1

Definitions

Gray scale: Color (n) → n indicates gray scale level

Data: 1=High, 0=Low



SPECIFICATIONS

TITLE: 10.4" HIGHEND TFT LCD MODULE

NUMBER: HLD 1045E REV. 1 PAGE 10 OF 18

6. BLOCK DIAGRAMM

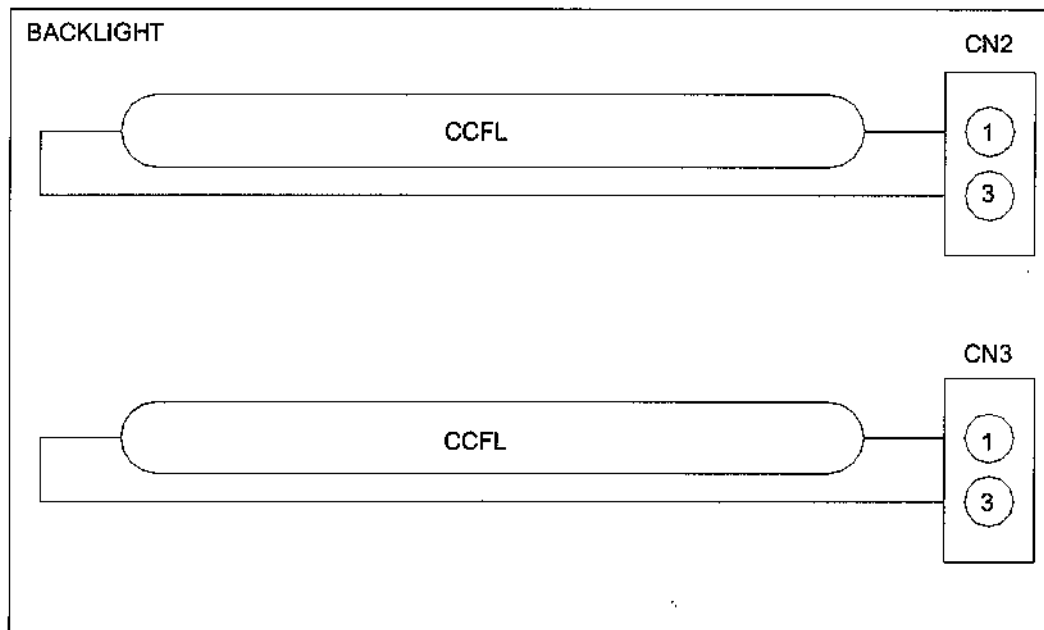
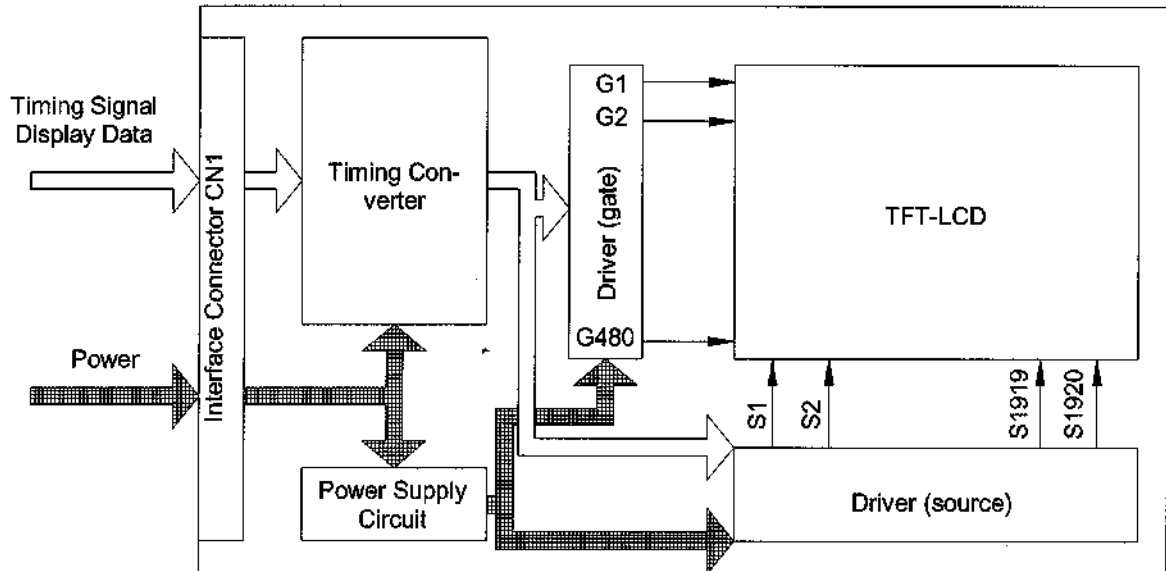



SPECIFICATIONS

TITLE: 10.4" HIGHEND TFT LCD MODULE

NUMBER: HLD 1045E REV. 1 PAGE 11 OF 18

7. MECHANICAL SPECIFICATION

7.1 Frontside Drawing

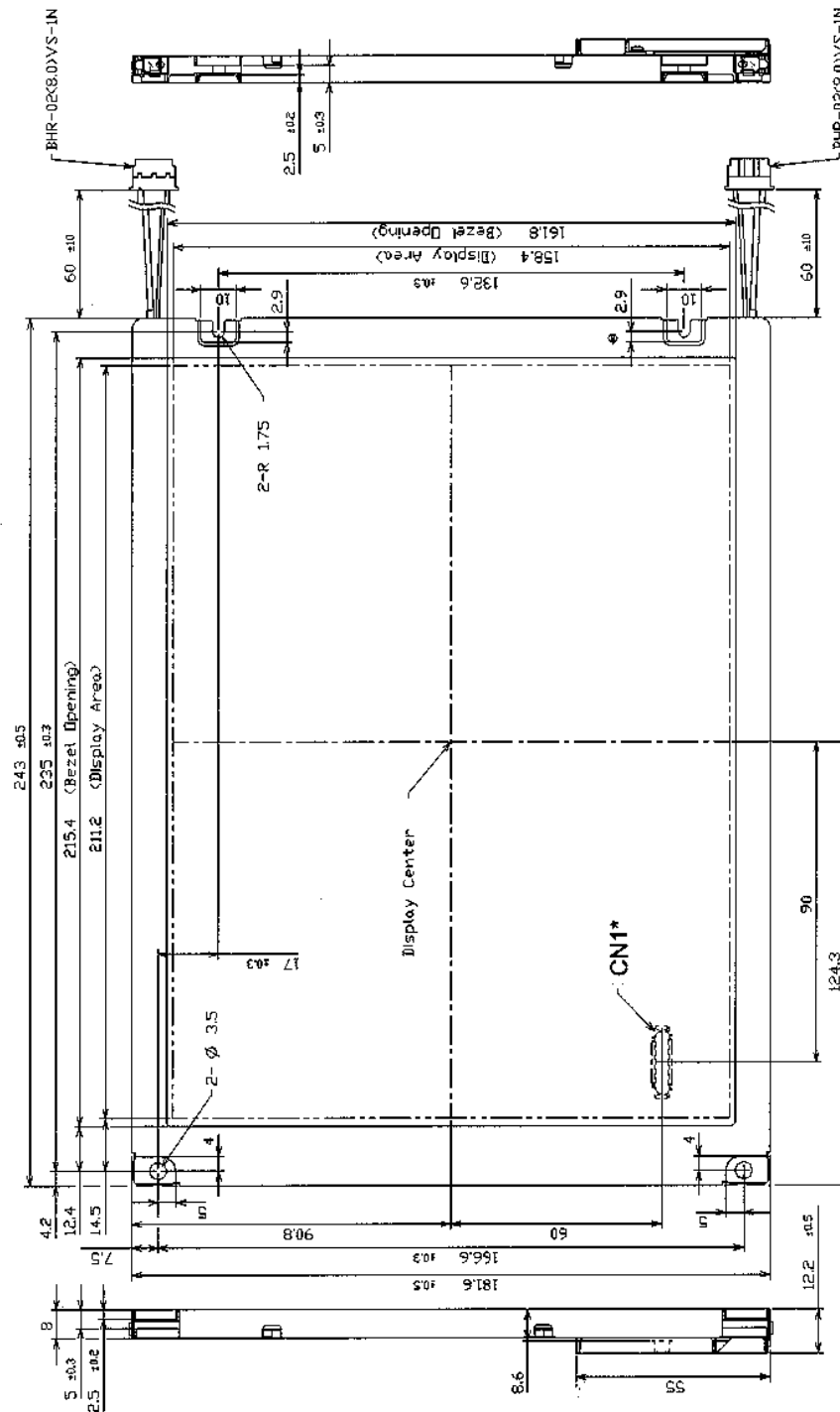

*Note: The connector CN1 is located on the rear side of the TFT-LCD module.
Undefined tolerances are ±0.5mm



SPECIFICATIONS

TITLE: 10.4" HIGHEND TFT LCD MODULE

NUMBER: HLD 1045E REV. 1 PAGE 12 OF 18

7.2 Rear Side Drawing

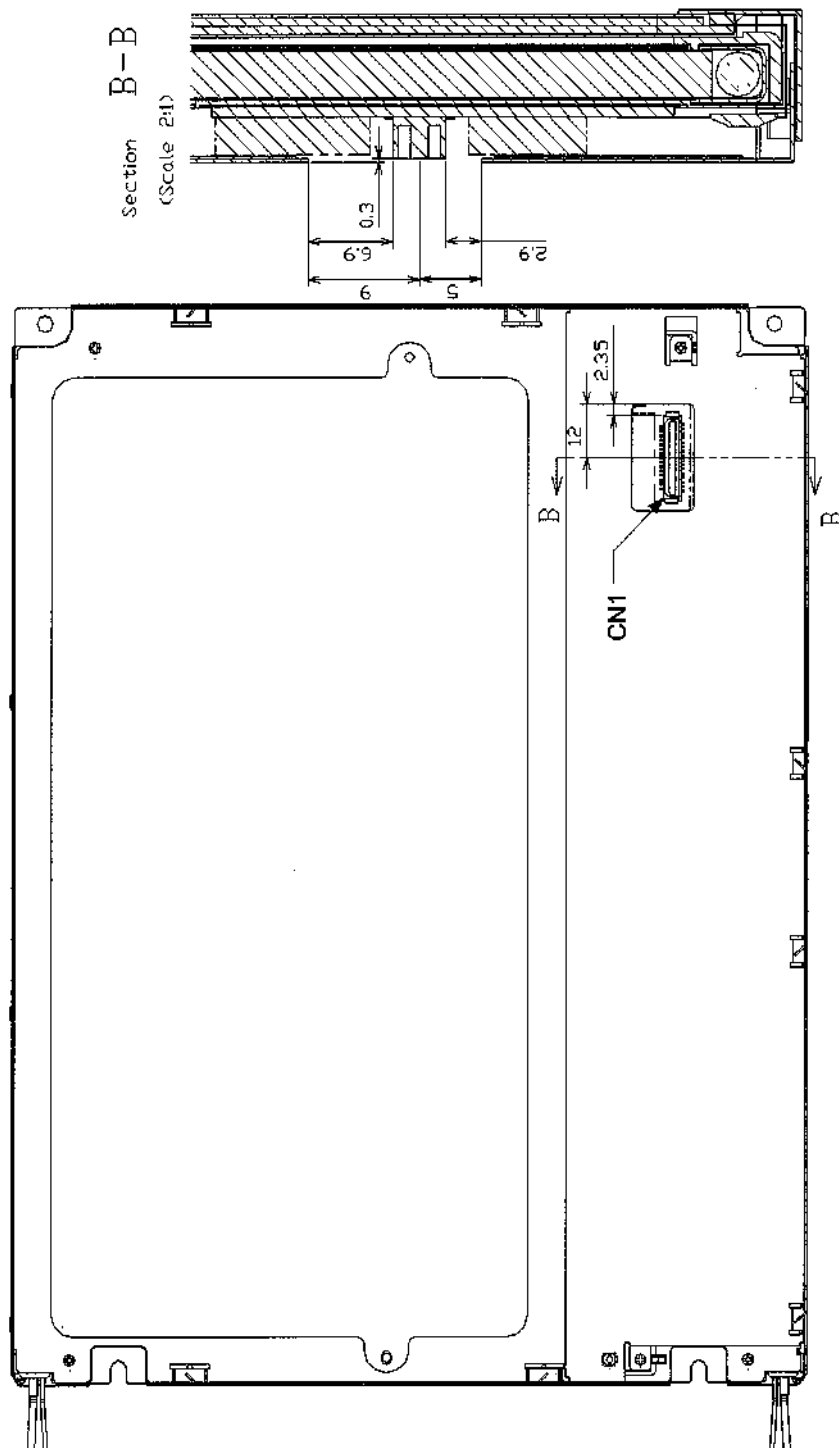



SPECIFICATIONS

TITLE: 10.4" HIGHEND TFT LCD MODULE

NUMBER: HLD 1045E REV. 1 PAGE 13 OF 18

8. OPTICAL CHARACTERISTICS

Test conditions: $T_a=25^{\circ}\text{C}$, $V_{CC}=5.0\text{V}$, $I_L=6.5\text{mA}$, all measurements made using BM-5A (TOPCON) or LCD-7000 (Otsuka Electronic) in a dark room, under no ambient light conditions.

8.1 Summary table:

ITEM		SYMBOL	CONDITION	MIN	TYP	MAX	UNIT
Contrast Ratio		CR	$\theta = \Phi = 0^{\circ}$	150	300 ¹	-	
Luminance		L	$\theta = \Phi = 0^{\circ}$	-	400 ¹	-	cd/m ²
Response Time		tr	$\theta = \Phi = 0^{\circ}$	-	15 ¹	-	ms
		tf	$\theta = \Phi = 0^{\circ}$	-	35 ¹	-	ms
Viewing Angle	Horizontal	Φ	CR \geq 10	-	-60~60	-	$^{\circ}\text{C}$
	Vertical	θ		-	-55~45	-	$^{\circ}\text{C}$
Color Coordinates	Red	x	$\theta = \Phi = 0^{\circ}$	0.54	0.57	0.60	-
		y		0.30	0.33	0.36	
	Green	x		0.30	0.33	0.36	
		y		0.49	0.52	0.55	
	Blue	x		0.14	0.17	0.20	
		y		0.15	0.18	0.21	
White	x	0.29	0.32	0.35			
	y	0.31	0.34	0.37			

1) Contrast, Luminance and response time will be influenced in upper and lower temperatur range

8.2 Definitions

Contrast Ratio CR = ON (White) Luminance / OFF (Black) Luminance

Viewing angle (θ , Φ) – see drawing below:

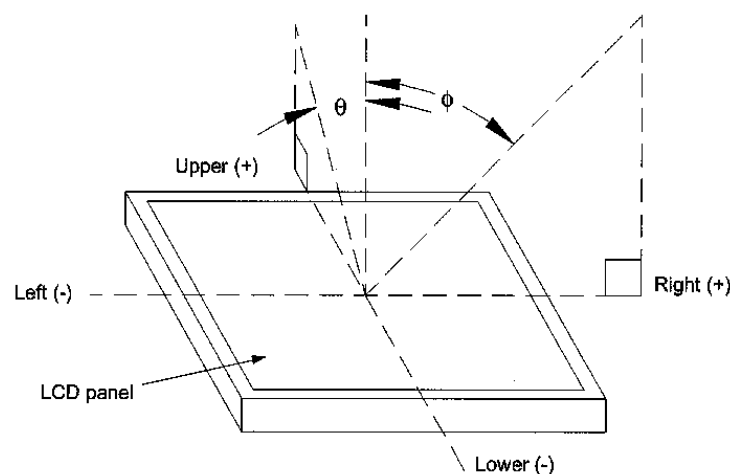



8.3 Definition of Response Time t_r and t_f :

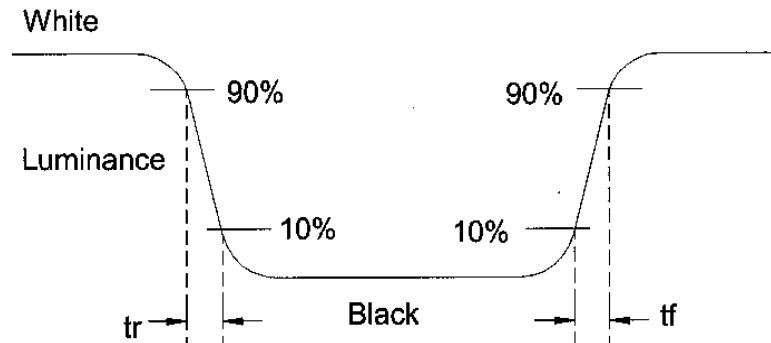

9. RELIABILITY TEST CONDITIONS

9.1 Temperature and Humidity

TEST ITEM	CONDITIONS
High temperature and high humidity operation	40°C, 90%RH 500 hours
High temperature and high humidity storage	60°C, 90%RH 96 hours
Low temperature storage	- 20°C, 96 hours
Thermal shock (non-operating)	between - 20°C (1 hour) and 60°C (1 hour) 5 cycles

9.2 Shock and Vibration

TEST ITEM	CONDITIONS
Shock (non operating)	Shock level: 1470 m/s ² (150G) Waveform: half sinusoidal wave, 2ms Number of shocks: one shock input in each direction of three mutually perpendicular axis for a total of six shock input
Vibration (non operating)	Vibration level: 9,8 m/s ² (1.0G) Waveform: sinusoidal Frequency range: 5 to 500 Hz Frequency sweep rate: 0.5 octave/min. Duration: one sweep from 5 to 500 to 5Hz in each of three mutually perpendicular axis (total 3 hrs.)

Judgment standard – Pass/Fail criteria for reliability tests is defined as follow:

Pass: normal display image with no obvious non-uniformity defect

Fail: No display image, obvious non-uniformity, or line defect.



10. LIFE TIME OF THE BACKLIGHT LAMP

Definitions

Lamp end of life is defined as the luminance of it become half of the initial value
The life time of the backlight lamp depends on the ambient temperature. The life time may be different from the time specified in the table below if the lamp is operated under extreme temperature conditions.

ITEM	SYMBOL	CONDITION	SPECIFICATION		UNIT
			MIN	TYP	
Life Time	T _L	IL=3.0mA, Ta=25°C	50,000	50,000	hours
		IL=6.0mA, Ta=25°C	40,000	50,000	
		IL=7.0mA, Ta=25°C	30,000	40,000	

11. HANDLING PRECAUTIONS FOR TFT-LCD MODULES

ASSEMBLY PRECAUTIONS

Please use the mounting hole on the module corners for installation and avoid bending or wrenching LCD during assembly process. Do not drop, bend or twist the TFT-LCD module during handling.

Guidelines for designing the TFT-LCD module enclosure:

- Housing case must be designed carefully so as not to put stresses on LCD all sides and not to wrench module. Mechanical stress to the TFT-LCD module made degrade the reliability and overall performances of the display (like brightness uniformity degradation...etc.).
- Keep sufficient clearance between LCD module back surface and housing when the LCD module is mounted. Approximately 1.0 mm of the clearance in the design is recommended taking into account the tolerance of LCD module thickness and mounting structure height on the housing.
- When some parts, such as, FPC cable and ferrite plate, are installed underneath the LCD module, still sufficient clearance is required, such as 0.5mm. This clearance is, especially to be reconsidered when additional parts are inserted for EMI countermeasures.
- Choose carefully the inverter location to avoid any stress to the lamp cable. The lamp cable also should not interfere with the module installation into the enclosure.
- Keep sufficient clearance between LCD module and the other components, such as inverter and speaker so as not to interfere with the LCD module. Approximately 1.0mm of the clearance in the design is recommended.
- Do not apply pressure or scratch LCD panel surface with anything hard. Do not soil LCD panel surface by touching with bare hands. (Polarizer film, surface of LCD panel is easy to be flawed.).



SPECIFICATIONS

TITLE: 10.4" HIGHEND TFT LCD MODULE

NUMBER: HLD 1045E REV. 1 PAGE 16 OF 18

- Do not apply pressure or any parts on the rear side such as source TCP, gate TCP, control circuit board and FPCs during handling LCD module. If applying pressure to the TFT-LCD module in unavoidable, handle the LCD module with care not to damage them.
- Wipe out LCD panel surface with absorbant cotton or soft cloth to clean the surface.
- Wipe out immediately any liquids which may have accidentally being sprayed on LCD panel surface. Droplets on the LCD panel surface may alter the quality of the image.
- Do not disassemble the TFT-LCD module for any reasons. By doing so you would void the warranty of thr TFT-LCD and is very likely that the performances will be degraded cosiderably.
- Do not touch metal frames with bare hands and soiled gloves. If fingerprints or dirt are not cleaned immediately with solvent it is very likely that permanent marks will be left on the metal surface.
- Disconnect the lamp wires before handling the inverter otherwise is possible to damage the lamp and/or the lamp wires by pulling it together with the inverter.

OPERATING PRECAUTIONS

- Turn off the power supply before connecting and disconnecting signal input cable.
- Do not change the setting of the adjustable resistors on the TFT-LCD module subassemblies. The adjustable resistors are properly set at the factory and any deviation from the factory setting will compromise the performances on the TFT-LCD module.
- When evaluating the optical characteristics of the display please note that will take longer time for the backlight to stabilize if the ambient temperature is at the lower end of the temperature range.
- Sudden changes of the ambient temperature may cause condensation on various surfaces of the TFT-LCD module and degrade the overall performances until the surface becomes dry again.
- Follow up the general safety rules applying to generic electronic products.

PRECAUTIONS WITH ELECTRONICS

- This LCD module uses CMOS integrated circuits and other components subject to be affected by electrostatic discharges. Use ESD protection equipment and follow all ESD safety procederes when handling the TFT-LCD modules.
- Please remove protection film very slowly from the surface of LCD module to prevent from high level electrostatic discharges. It is recommended to lift the protection film starting from the corner of the glass in proximity of the source and gate PWB ending at the corner of the glass furthest away from the electronics.



STORAGE PRECAUTIONS

- When you store LCDs for a long time, it is recommended to keep the temperature between 0°C ~ 40°C without the exposure of sunlight and to keep the humidity less than 90%RH.
- Do not leave the LCDs in the environment of high humidity and high temperature such as 60°C 90%RH, 80°C with low humidity only.
- Do not expose the TFT-LCD modules to temperatures below -35°C.

SAFETY PRECAUTIONS

- When disposing LCDs it is recommended to break them into pieces. The broken pieces should be washed with solvents such as acetone and ethanol. The residual solvent from this process should be burned.
- If any liquid leaks out of damaged glass cell and corners in contact with the hands, wash it thoroughly with soap and water.

OTHERS

- Exposing the TFT-LCD module to strong incident light may negatively affect the display characteristics because of polarizer film, color filter and other materials degradation. Do not expose LCD module to direct sunlight or light with strong ultraviolet content.
- Avoid any contact of the TFT-LCD module front surface with other objects or materials.

PACKAGING AND SHIPPING

- Packaging box and inner case for LCD are designed to protect the LCDs from the damage or scratching during transportation. Do not open the packaging box unnecessarily.
- Do not stack more than 5 boxes on top of each other because stack of 5 is minimum designed limit. Do not turn over the boxes.
- Avoid excessive shock, the shipping boxes are not designed to be thrown, Excessive vibrations can also damage the boxes and the TFT-LCD modules inside.
- Packaging box and inner structures of it are made of cardboard. Avoid to have the boxes in contact with water or in high humidity environment which may cause the carton to become soft, or to break, damaging the TFT-LCD modules.



CONTENTS

1.	OVERVIEW	2
1.1	Description	2
1.2	General Features.....	2
1.3	Product Disclaimer	2
2.	ABSOLUTE MAXIMUM RATINGS	3
2.1	Environmental conditions	3
3.	ELECTRICAL CHARACTERISTICS	3
3.1	Conditions	3
3.2	Backlight	3
3.3	Notes	4
4.	INTERFACE CONNECTORS PIN ASSIGNMENT	5
5.	INTERFACE TIMING	7
5.1	Timing Chart.....	7
5.2	Timing Specification	8
5.3	Color Data Assignment	9
6.	BLOCK DIAGRAMM	10
7.	MECHANICAL SPECIFICATION	11
7.1	Frontside Drawing	11
7.2	Rear Side Drawing.....	12
8.	OPTICAL CHARACTERISTICS.....	13
8.1	Summary table	13
8.2	Definitions	13
8.3	Definition of Response Time t_r and t_f :	14
9.	RELIABILITY TEST CONDITIONS	14
9.1	Temperature and Humidity.....	14
9.2	Shock and Vibration	14
10.	LIFE TIME OF THE BACKLIGHT LAMP	15
11.	HANDLING PRECAUTIONS FOR TFT-LCD MODULES	15